

BRONZE GATE VALVE

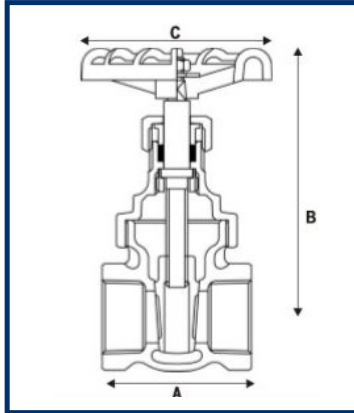

| DIMENSIONS | | | | | | |
|--------------|--------|-------|-------|--------|--------|-------|
| Size mm (in) | 15 (½) | 20(¾) | 25(1) | 32(1¼) | 40(1½) | 50(2) |
| A (mm) | 48 | 52 | 59 | 63 | 67 | 74 |
| B (mm) | 78 | 94 | 109 | 120 | 142 | 163 |
| C (mm) | 53 | 64 | 69 | 80 | 89 | 102 |
| Weight (kg) | 0.3 | 0.5 | 0.7 | 1.0 | 1.3 | 1.9 |

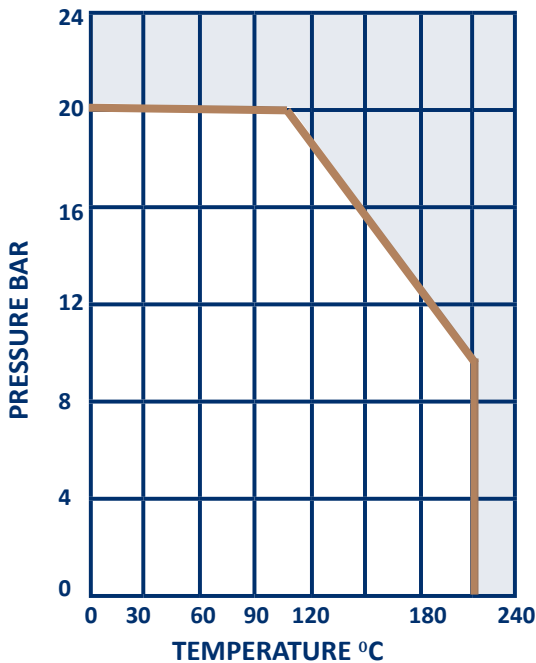

PRESSURE/TEMPERATURE RATING

- PN20
- 9 Bar at 180°C
- 20 Bar from -10 to 100°C

TEST PRESSURES

- Shell : 30 Bar
- Seat : 22 Bar
- BS EN 12266

SPECIFICATION

- BS EN 12288
- Non-rising stem
- Threaded bonnet
- Bronze seat faces
- Threaded BS EN 10226 (ISO 7 Rc)

| MATERIAL SPECIFICATION | | | |
|------------------------|-----------|----------------|------------|
| | | SPECIFICATION | |
| COMPONENT | MATERIAL | BS EN | ASTM |
| Body | Bronze | 1982 CC491K | B62-C83600 |
| Wedge | Bronze | 1982 CC491K | B62-C83600 |
| Bonnet | Bronze | 1982 CC491K | B62-C83600 |
| Stem Nut | Brass | 12164 CW603N | B16-C36000 |
| Gland Packing | PTFE | | |
| Gland | Brass | 12164 CW603N | B16-C36000 |
| Gland Nut | Brass | 12164 CW603N | B16-C36000 |
| Stem | Brass | 12164 CW603N | B16-C36000 |
| Handwheel | Cast Iron | 1561 EN-JL1030 | A126 CI B |
| Nameplate | Aluminium | | |
| Handwheel nut | Steel | | AISI 1010 |